

User and installation manual

Boiler stove Rosanna



NORDIC FIRE

Table of contents

Introduction.....	4
The boiler stove.....	4
Combination with solar collectors or a heat pump.....	4
Technical data.....	5
Assembly.....	8
Delivery of the stove	8
The right setup location.....	8
Connection to the flue pipe.....	9
Safety.....	9
Draft and efficiency	9
Preventing condensation.....	9
Cleaning and maintenance	9
External air supply	10
Connection to the central heating system.....	11
Connections on the stove.....	11
Connection to existing central heating system.....	12
Connection to buffer or cylinder tank.....	13
The technology	14
Thermal safety (temperature protection).....	14
Overpressure protection.....	14
Thermal mixing valve	14
Filling and bleeding.....	15
Commissioning.....	16
Firing the stove	16
First use	16
Lighting the stove.....	16
Additional tips for stoking your stove.....	16
Heating capacity of the stove.....	17
Correct operation.....	17
Nuisance and environment	18
Checking various functions	18
Thermal temperature protection	18
Wood as a fuel.....	19
Wood suitable for stoking a wood-burning stove.....	19
How much wood can you fire?	20
Cleaning and maintenance.....	21
Normal maintenance.....	21
Cleaning the glass window.....	21
Cleaning of painted parts.....	21
Cleaning the inside and heat exchanger	21
Special maintenance.....	21
Maintenance of seals.....	21

Cleaning the fireplace and flue system.....	21
Mounting glass pane	21
Door closure	21
Vermiculite or chamotte stone	21
Warranty conditions	22
Deviations	23
Service and faults	23

Introduction

Dear customer

You have chosen a modern central heating wood stove that can be connected to the existing central heating system. This allows you to heat several rooms by firing wood.

This manual is designed to help you use and maintain the appliance effectively and to ensure that you get the most out of your boiler wood stove.

This manual provides detailed instructions on how to install, use and maintain the stove. It also contains information on the functions and controls, as well as tips and recommendations.

To use the appliance safely, it is important to read this manual carefully and follow the instructions. Read this manual completely before using the appliance for the first time, and keep it in a safe place for future reference.

If you have any questions or problems while using the device, refer to this manual for help. If you still encounter problems, contact your supplier for further support.

Nordic Fire wishes you much heating pleasure!

The boiler stove

A boiler wood stove is an advanced type of wood stove that not only provides warmth and ambience, but is also used to provide hot water to a central heating system in your home. It is an efficient and sustainable heating solution that will reduce the use of fossil fuels such as gas or oil.

The central heating wood stove has a built-in heat exchanger that transfers the hot water produced by burning wood to your home's existing heating system. This water can be used for radiators, underfloor heating or even for heating your domestic water.

Installing a central heating wood stove and connecting it to the existing heating system requires specialist knowledge. It is advisable to consult a professional installer to ensure the system is installed correctly and complies with applicable safety and building regulations.

Combination with solar collectors or a heat pump

It is possible to combine your central heating wood stove with solar collectors or a heat pump to create a hybrid heating system. This makes it possible to theoretically save 100% on gas consumption. The installer can look into the possibilities of this.

Note: the boiler wood stove cannot be used as a main heating system. It can, however, be used as additional heating!

Technical data

1. Number of the declaration of performance / Uniek nummer prestatieverklaring / Nummer Leistungserklärung / Numéro déclaration des performances	C-855
---	--------------

Unique identification product-type / Uniek identificatiecode producttype / Eindeutiger Kenncode de Producttyp / Code d'identification unique du produit typ	Rosanna CV
Type, batch or serialnr. / Type-, partij- of serienummer / Typen-, Chargen- oder Seriennummer / Numéro de type, de lot ou de série	Rosanna Wasser
Intended use of product / Beoogd gebruik van product / Bestimmungsgemäße Verwendung des Produkts / Utilisation prévue du produit	Residential space heating appliance fuel by wood / Product om woonruimte verwarmen middels stoken hout / Gerät zum Heizen von Haushalten mit Holz / Appareil de chauffage domestique alimenté au bois
Contact address of the manufacturer / Contactadres van de fabrikant / Kontaktadresse des Herstellers / Adresse de contact du fabricant	Nordic Fire B.V. De Immenhorst 5 7041 KE 's Heerenberg The Netherlands
System or systems of assessment and verification of constancy of performance of the construction product as set out in Annex V / Het systeem of de systemen voor de beoordeling en verificatie van de prestatiebestendigheid van het bouwproduct vermeld in Bijlage V / Systeme zur Bewertung und Kontrolle der Konstanz der Leistungsfähigkeit de Bauprodukts (AVCP) / Le ou les systèmes d'évaluation et de vérification de la constance des performances du produit de construction, conformément à l'annexe V	System 3 / Systeem 3 / System 3 / Système 3
Notified Body / Keuringsinstantie / Notifiziertes Labor / Laboratoire notifié	EMÍ-TÜV SÜD Kft.
Test rapport number / Testrapportnummer / Numéro du rapport de test	R-1071965-2

2. Declared performance / Aangegeven prestatie Erklärte Leistung / Performance déclarées	EN 13240: 2001: + A2:2007
---	----------------------------------

Description / Beschrijving / Beschreibung / Description	Performance / Prestatie / Leistung / Performances	
Fire safety / Brandveiligheid / Brandwiderstand / Sécurité incendie		
Distance to combustible materials / Afstand tot brandbare materialen / Abstand zu brennbaren Materialien / Distance minimale à respecter par rapport aux matériaux combustibles adjacents	Minimum distances / Minimum afstanden / Mindestabstände / Distance minimale	
	Rear / Achterzijde / Hinten / Arrière	200 mm
	Sides / Zijkanten / Seiten / Côtés	200 mm
	Front / Voorzijde / Vorseite / Defant	800 mm
Risk of burning fuel falling out / Risico op eruit vallen van brandende brandstof / Gefahr durch Herausfallen von brennendem Heizmaterial / Risque de projections de braises	Pass / Voldoet / Bestanden / Conforme	

2. Declared performance (continuation) / Aangegeven prestatie (vervolg)
Erklärte Leistung (Folge) / Performance déclarées (suite)

EN 13240: 2001: + A2:2007

Description / Beschrijving / Beschreibung / Description	Performance / Prestatie / Leistung / Performances	
Emission of combustion products / Emissie van verbrandingsproducten / Emission von Verbrennungsprodukten / Émissions provenant de la combustion	CO (mg/Nm ³ 13% O ₂)	1179
	Dust (≤40 mg/Nm ³ 13% O ₂) Fijnstof (≤40 mg/Nm ³ 13% O ₂) Staub (≤40 mg/Nm ³ 13% O ₂) poussière (≤40 mg/Nm ³ 13% O ₂)	61
Chimney draft / Schoorsteentrek / Förderdruck / Tirage de cheminée	Pa	12.0
Flue gas mass / Rookgasmassa / Abgasmassenstrom / Masse des fumées	g/s	9.7
Cleanability / Reinigbaarheid verbrandingskamer / Reinigung / Possibilités de nettoyage	Pass / Voldoet / Bestanden / Conforme	
Flue gas temperature at nominal heat output / Rookgastemperatuur bij nominaal vermogen / Rauchgastemperatur bei nomineller Heizleistung / Température des fumées dans le conduit de raccordement en fonctionnement nominal	T (°C]	197
Vermogen		
Nominal heat output / Nominaal vermogen / Nominelle Leistung / Puissance nominale	kW	9.5
Water heating output / Waterzijdig vermogen / Leistung Wassererwärmung / Puissance de chauffage de l'eau	kW	6.2
Energy efficiency / Rendement / Wirkungsgrad / Rendement	%	81.8

The efficiency of the above product corresponds to the declared performance. The above-mentioned manufacturer is solely responsible for drawing up the declaration of performance in accordance with the Regulation (EU) no. 305/2011.

De prestaties van bovenstaand product komen met de verklaring overeen. Voor de opstelling van de prestatieverklaring overeenkomstig verordening (EU) Nr. 305/2011 is alleen de bovengenoemde fabrikant verantwoordelijk.

Die Leistung des vorstehenden Produkts entspricht der erklärten Leistung/den erklärten Leistungen. Für die Erstellung der Leistungserklärung im Einklang mit der Verordnung (EU) Nr. 305/2011 ist allein der obengenannte Hersteller verantwortlich.

La performance du produit susmentionné est conforme à la performance déclarée/aux performances déclarées. L'établissement de la déclaration de performance conformément au règlement UE n° 305/2011 est la seule responsabilité du fabricant susmentionné.

Signed for and on behalf of the manufacturer by:

Ondertekend namens de fabrikant door:

Unterschreibe für und im Namen des Herstellers von:

Signé au nom du fabricant par:

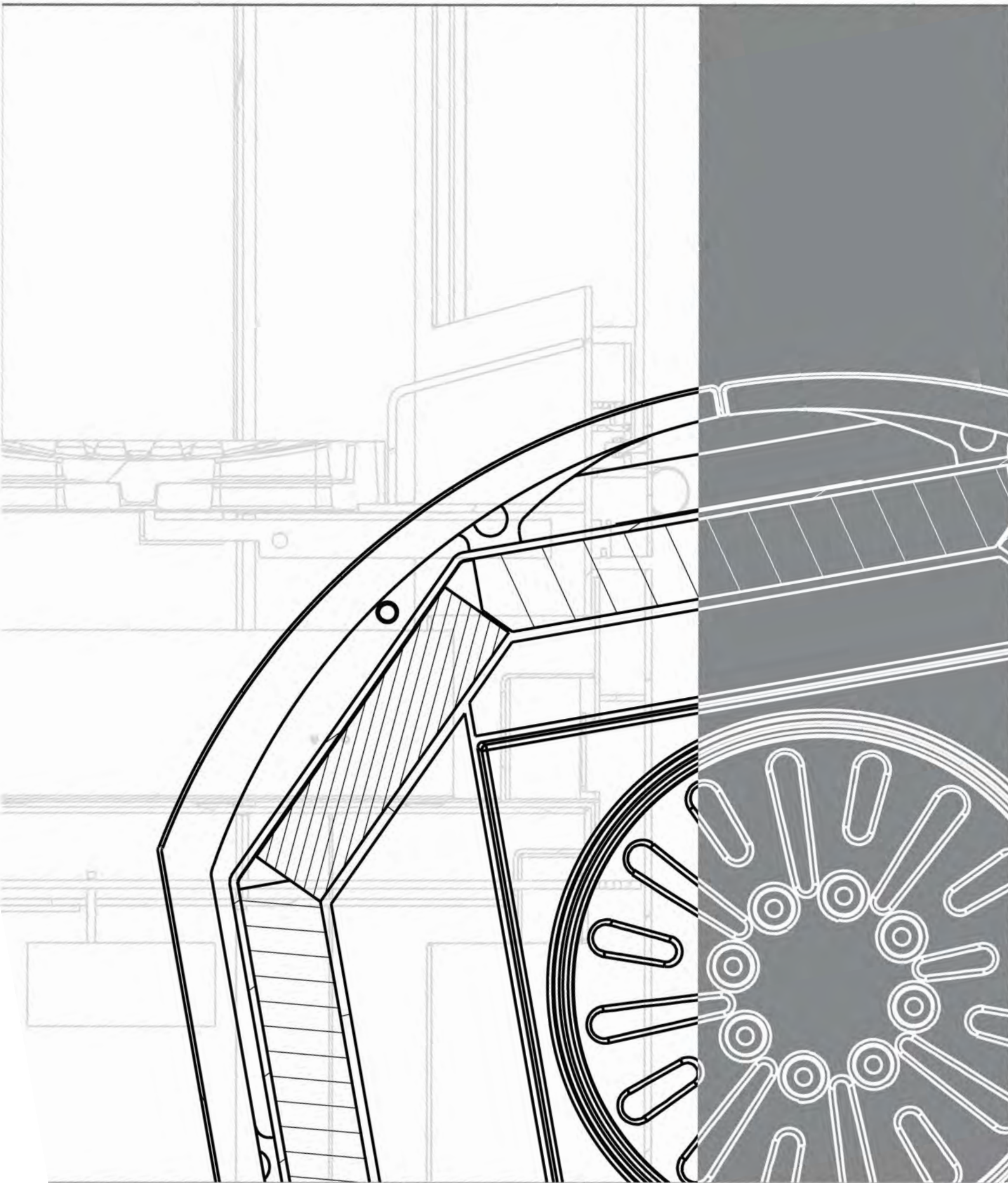

Assembly

Delivery of the stove

Check carefully that the stove is in undamaged condition. Please check that no transport damage has occurred. You should report any damage to the carrier.

Damage to the glass or vermiculite after commissioning is almost always caused by overloading or incorrect operation. In this case, a warranty claim is not possible.

The right setup location

- Ensure that the installation location is chosen to allow a straight connection to the chimney. The exact requirements will be specified by your installer or Nordic Fire dealer.
- Nordic Fire's boiler wood stoves are usually fitted with a top connection. A rear connection is not possible.
- The installation location must be flat and level before setting up the stove. If the stove is not positioned correctly, excess air may not be able to escape from the stove.
- The floor on which the central heating stove will be placed must be made of a non-flammable material. The floor plate must protrude at least 50 cm at the front and 30 cm at the side. So that no heat can be transferred to the combustible floor.
- The flue materials should maintain sufficient distance from combustible materials. The distances indicated on the rating plate and in this manual must be maintained.
- You must ensure that there are no combustible materials directly in the radiant area of the glass pane.

Connection to the flue pipe

The connection to the chimney should be provided and checked by a recognised installer. The Nordic Fire dealer can check whether the flue and chimney are sufficiently safe. In addition, he will check whether the flue meets the valid regulations.

The necessary connecting materials for the chimney are not part of the delivery of the stove. These materials are provided by the installer. In any case, the diameter of the chimney must be at least the diameter of the stove pipe mouth. A larger diameter is possible, a smaller diameter is not allowed.

Wood-burning stoves are complex technical devices. A safe and trouble-free connection is important here. Regulations should be observed in this regard.

The flue of a boiler wood stove plays a crucial role in the safety, operation and efficiency of your stove.

Safety

A properly functioning flue ensures the proper removal of combustion gases, smoke and harmful substances, such as carbon monoxide, released during the combustion process. Carbon monoxide is a colourless and odourless gas that can be life-threatening if inhaled. The flue prevents these gases from entering the room, reducing the risk of poisoning and health problems.

Draft and efficiency

A proper flue ensures adequate draft, also known as chimney draft. Chimney draft is essential for proper wood combustion and efficient stove operation. A good draught ensures sufficient air supply and optimum combustion, where the wood is fully consumed and the heat is efficiently utilised. Poor draught can lead to incomplete combustion, reduced efficiency and creosote formation.

Preventing condensation

During the combustion process, water vapour is produced that is present in the flue gases. Upon cooling, this water vapour can condense and mix with the flue gases, creating creosote. Creosote can accumulate in the flue gas duct and lead to corrosion, blockages and increased fire risk. A properly constructed and insulated flue gas duct ensures efficient removal of condensation, extending the life of the duct and reducing the risk of creosote development.

Cleaning and maintenance

The flue pipe requires regular maintenance and cleaning. Regular inspection and cleaning of the flue gas duct help remove accumulated creosote, reducing the risk of chimney fire. Moreover, a clean flue can improve the efficiency of the stove by ensuring unobstructed airflow. The flue should be cleaned at least annually by a recognised chimney sweep.

A central heating wood stove is prone to insufficient chimney draft. This can cause smoke to enter the room during refuelling.

Important when connecting to the chimney:

- The chimney must be checked in advance by the Nordic Fire installer for leaks and the condition of the chimney.
- A brickwork, uninsulated flue is not allowed! A masonry flue must be lined with a suitable inner pipe which is insulated. For example, with vermiculite granules. The lining must be smooth and at least the diameter of the stove. Minimale trek in het kanaal is tenminste 17 Pa.
- This draft should be measured in advance to ensure that the draft in the flue is sufficient. As soon as the chimney draft exceeds 20 Pa, a draft limiter should be installed. If the draft is in the flue, smoke may enter the room when opening the door.
- All flue gas connections must be tight
- It is not allowed to connect more than one stove to a chimney.
- If the draught is insufficient, smoke may enter the room when filling the stove. You can prevent this to some extent by carefully opening the door slightly first and then slowly all the way in before topping up with wood.

CAUTION: A boiler wood stove with a high efficiency (read: high resistance) is susceptible to an improperly functioning chimney.

We recommend using a fully insulated duct with a diameter of at least the connection of the stove. A larger diameter will improve draught and is therefore advisable. Bends in the duct should be avoided as much as possible. A brick channel is not allowed, as it can cause too many problems with the draught due to cooling and resistance.

External air supply

The boiler wood-burning stove is equipped with an external air supply which can be used in a poorly ventilated house (passive / new-build house). However, the wood stove is not completely sealed. If a negative pressure situation may arise, additional ventilation should be provided to prevent this. Even if the stove is connected with an external air supply!

This external air supply can be connected to the outside air or other ventilated room if the room is insufficiently ventilated.

Please note that an extractor fan present in the room or adjoining room can cause a large air extraction which can suck smoke gases out of the stove. An extractor hood without external ventilation must not be used at the same time as the wood stove.

The external air connection must not be reduced. The length may be a maximum of 5 metres with a maximum of two 90-degree bends. In addition, care should be taken to ensure that the air supply cannot be blocked by small animals. A grille is necessary for this purpose.

- If there is an underpressure situation in the installation room, the stove must not be put into operation. Contact your dealer for this.
- When connecting the external air supply to the outside, cold moist air can enter the stove. This can cause rust if no measures are taken when the stove is not in use.
- If the external air supply is not connected, always ensure adequate ventilation.

The installer can determine whether the external air supply should be connected. This depends entirely on your living situation.

Connection to the central heating system

A central heating wood stove functions well if it is properly connected to the central heating system. However, once this is not done, or if the stove is not suitable for the central heating system, the radiators or underfloor heating may not heat up optimally.

The guarantee on the boiler wood stove is only applicable if it has been installed by the Nordic Fire dealer - installer. They should observe this manual as well as the applicable legal regulations. Annually, the cooling coil should be checked for leaks. They should also check that the cooling protection and overpressure protection can function properly.

Connections on the stove

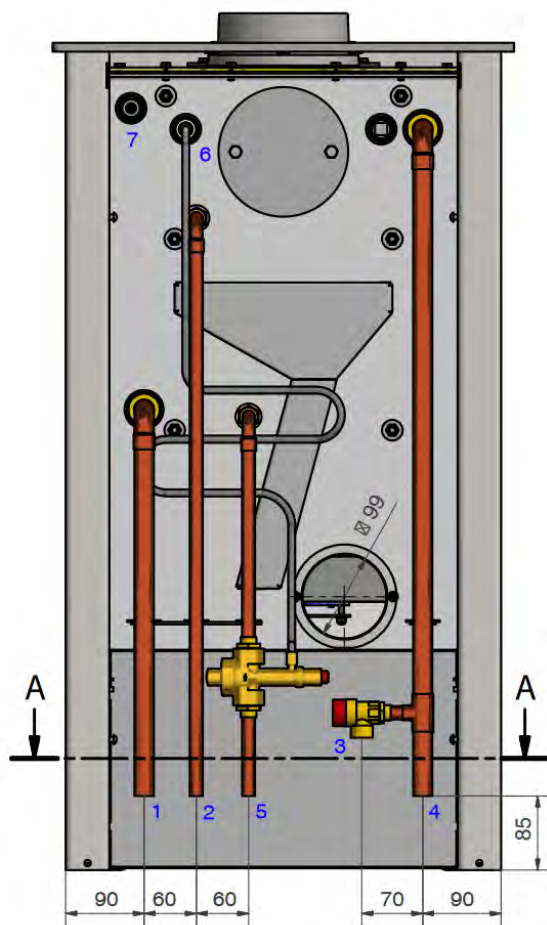

1. Returledning från tank \varnothing 22mm
2. Kallvatten kylslinga ut \varnothing 15mm
3. Säkerhetsventil 1/2" - 3/4"
4. Framledning till tank \varnothing 22mm
5. Kallvatten kylslinga in \varnothing 15mm
6. Dykrör överhettningssventil 1/2"
7. Dykrör givare styrning

Connection diagram for boiler stoves with built-in cooling coil

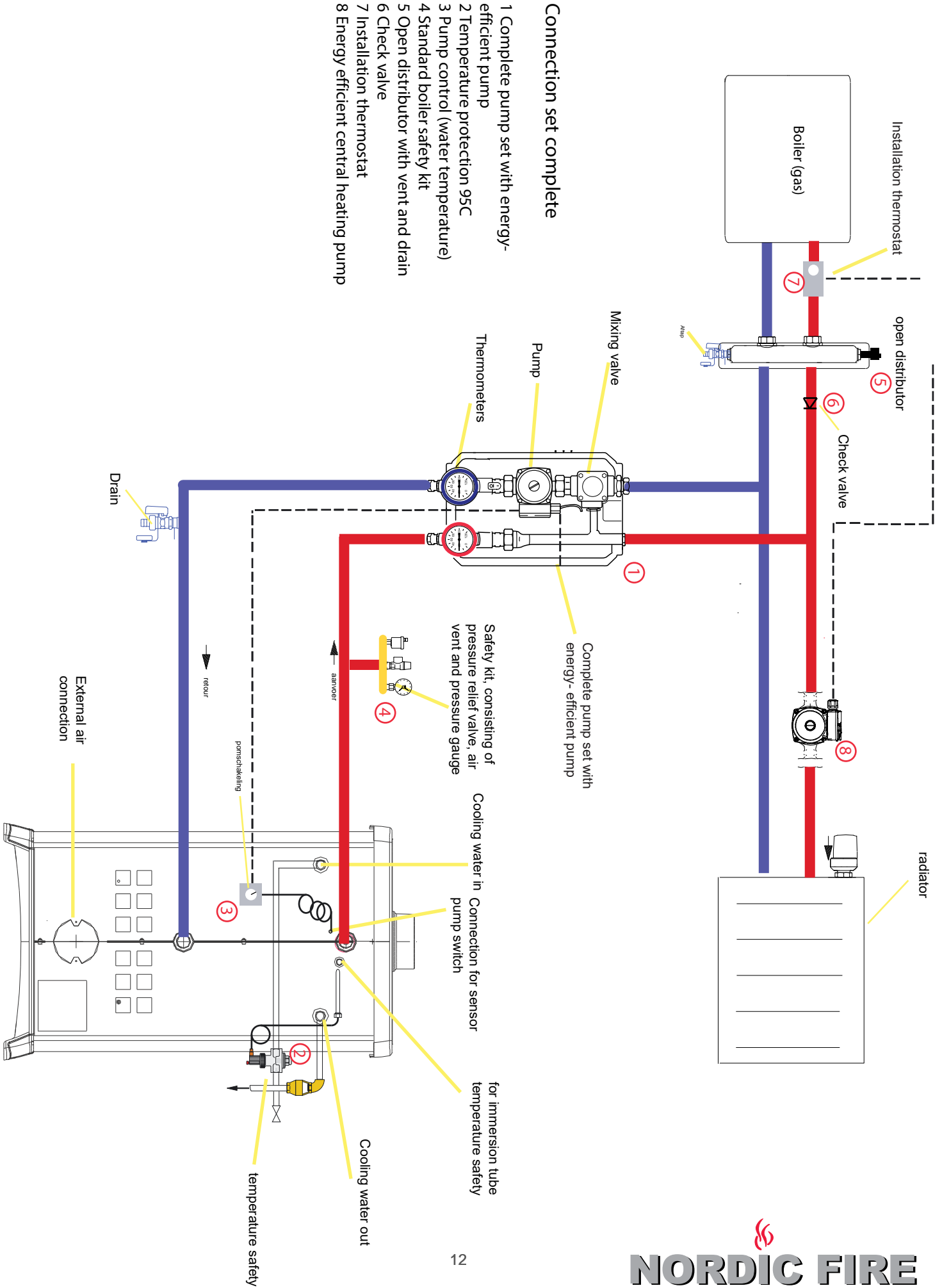

Connection set complete

- 1 Complete pump set with energy-efficient pump
- 2 Temperature protection 95C
- 3 Pump control (water temperature)
- 4 Standard boiler safety kit
- 5 Open distributor with vent and drain
- 6 Check valve
- 7 Installation thermostat
- 8 Energy efficient central heating pump

The technology

Thermal safety (temperature protection)

In the Netherlands, it is compulsory for a boiler wood stove to be fitted with a cooling coil, which is integrated in the heat exchanger. This cooling coil must be fitted with a temperature safety device 95 degrees. As soon as the temperature in the stove gets too high, cold water will flow through the cooling coil, indirectly cooling the central heating water. The water supply that is connected should not be able to be shut off.

The temperature safety device is an emergency cooling device and can fail after it has cooled the heater by overheating. The temperature safety device must then be replaced immediately.

A central heating wood stove without a (working) cooling coil and temperature safety device must not be put into operation.

Important:

1. For trouble-free operation, the water pressure should be between 0.8 and 2.5 bar.
2. It must not be possible to shut off the water supply manually.
3. The drain must be discharged into the sewer via a funnel.
4. The drain line must be free.
5. Temperature protection should be checked annually.

If the water pressure drops, the central heating wood stove should not be used.

Overpressure protection

A central heating wood stove should be fitted with an overpressure safety device. This means that it should be connected in open connection with the stove. The outlet of the pressure relief device should be in a frost-free zone. The outlet should be visible and lead into a funnel. This pressure relief device should be checked annually.

Warning: During operation of the central heating wood stove, steam or hot water may flow from the pressure relief valve. Do not close the outlet.

Thermal mixing valve

A thermal mixing valve is necessary to install with the central heating wood stove. The opening temperature of the mixing valve should be at least 60 degrees. A thermal mixing valve prevents deposits of creosote in the chimney and stove during operation. Only at start-up can some creosote form.

At the start-up of the boiler wood stove, the thermal mixing valve ensures that the water flows directly back to the stove via the bypass. This heats up the central heating stove before it releases heat to the central heating system. This also keeps the temperature in the stove at least 60 degrees.

Warning: Without a 60-degree thermal mixing valve, there is an increased risk of chimney fire in the short term!

Filling and bleeding

Proper venting of the central heating system is necessary to ensure proper operation of the boiler wood stove. Make sure there are sufficient vents at high points at branch points. Venting the system is often problematic and can take a long time.

Tips on filling and bleeding:

- The heating and especially the pumps should be switched off.
- Filling should be done via the return.
- The bleed valves should be opened before filling. The valve should be closed immediately as soon as water comes out.
- Open the filling valve slowly when filling
- The pump can be vented by opening the central screw. A pump can make noise. This is mainly caused by air. This air is difficult to remove and may take a longer time.
- For trouble-free operation, the water pressure should be between 0.8 and 2.5 bar.

Commissioning

Important to know:

- A central heating wood stove should never be used if it is not connected to the central heating system. High temperatures can damage the heat exchanger.
- In case of prolonged power failure, one should not refill wood and stop firing.
- When installing the central heating wood stove and connections, follow the applicable guidelines.
- Check that the connection to the chimney is completely sealed.
- The stove becomes very hot when in use.
- Make sure that no flammable materials are placed near the stove.
- The stove door should be kept closed as much as possible. Even when not in use.
- As far as possible, avoid overheating the stove with too much wood, which will shorten the lifespan of the boiler wood stove.
- Never use petrol, spirit or other lighter fluids
- Make sure that the stove's air supply is not blocked.
- The ash drawer must not be completely filled with ash. This may block the supply air. The grate may also overheat.
- Ensure adequate air supply, aeration of the staging area
- Be aware that an exhaust hood and the same or adjoining room can cause underpressure. This may draw flue gas from within the stove. It is important that the extractor is not used at the same time as the boiler wood stove once an underpressure situation may arise.
- Ash should only be removed once the wood stove has cooled down completely. Ensure that the ashes have cooled down completely before removing them.
- Always use a heat-resistant glove when operating the stove.
- Observe minimum distances from combustible materials. These can be found in this manual.

Firing the stove

First use

When you use the wood stove for the first time, the stove has to 'fire up'. Ventilate the room well while stoking. Make sure no cooker hood is on in the same room while the fire is burning; a cooker hood draws off combustion air that the fire needs.

Lighting the stove

- Open the air slider fully while lighting the stove
- Fill the stove bottom with a layer of wood. Place small wood on top and make sure there is enough kindling on top. Ignite this kindling with firelighters suitable for wood-burning stoves. Starting the fire on top creates less creosote when the stove starts up
- Leave the door ajar so that sufficient air can enter the stove at start-up. You should stay with the stove as long as the door is ajar. After the stove has warmed up, the door can be closed.
- When the stove is warm, the air slider can be retracted slightly, but the air slider should never be closed completely!
- A single air slider stove controls both primary (combustion air) and secondary (post-combustion air) air supply. Up to the first half you control primary air supply, the second half the secondary air supply.

Additional tips for stoking your stove

This wood stove should be fired as hot as possible to achieve good combustion. Smothering the stove will result in poorer combustion which may lead to chimney fire. It is not allowed to close the air slider completely.

It is not possible to keep the stove burning at night. If you add wood in the evening, it will normally burn out after a few hours. You cannot 'keep' the stove burning overnight. A smouldering / choked combustion leads to nothing. It only makes your chimney and your surroundings more polluted. Het is niet mogelijk om de kachel 's-nachts door te laten branden. Indien u 's-avonds hout bijvult is dit normally burn up after a few hours. You cannot 'hold over' the stove at night. A smouldering / choked combustion leads to nothing. It only makes your chimney and your surroundings more polluted.

A choke valve in the chimney is not allowed.

Heating capacity of the stove

The actual output of the stove is largely determined by the amount of wood fired. As a rule of thumb:

1 kg of wood corresponds to 3 kW of power.

The capacity of the stove is indicated on the rating plate. This is the output that is achieved with the prescribed amount of wood during inspection. Stoking less wood leads to less power. Stoking more wood leads to a higher output. However, it must be taken into account that the stove does not overheat.

The capacity of the boiler wood stove is tested during the inspection and indicated on the rating plate of the stove. Depending on the capacity, you can heat more or less. The space you can actually heat depends on the amount of fuel, the chimney draft and the insulation level of your home. Values issued for this reason are different in each case because not all other conditions are equal.

Correct operation

Stoves are designed to deliver maximum efficiency. A well-fired wood stove can achieve an efficiency of around 85%. This means you need less wood for the same amount of heat. Moreover, a well-fired stove will produce less smoke pollution.

Some tips for optimum firing pleasure:

- Always fire your stove with the door closed.
- Do not put more than 3 logs on the fire at once. A lot of fuel at once counteracts efficient combustion and pollutes the environment.
- Ventilate the room well when your stove is burning.
- Never turn on your extractor when your stove is burning in the same room.
- Feed additional air to your wood stove only when you start firing. If you constantly supply a lot of primary air, the efficiency will be much lower.
- Do not fire in fog or windless weather. In windless weather, there is hardly any draught in the cold chimney. As smoke is heavier than air, there is a chance that smoke will enter the room. In fog, the smoke from the chimney (outside) will cool quickly, drop down and cause a nuisance in your area.
- Do not extinguish the fire suddenly with water but let it burn out. The materials inside the fireplace may deform or crack due to sudden, large temperature differences.

Note: You control the heat output not by operating the air slider, but by the amount of wood you fill the stove with.

Nuisance and environment

Wood firing is a natural process that releases as much CO₂ as during decay in the forest. However, poor combustion can release harmful fumes. That is why it is imperative that you, the user, fire correctly to avoid nuisance. Provide dry, clean wood and do not fire during foggy weather. Regel de hoeveelheid warmte niet middels de luchtschuiven, maar middels de hoeveelheid hout. Het volledig knijpen van de luchttoevoer kan een slechtere verbranding met zich meebrengen.

Checking various functions

To ensure the stove is functioning properly, it is necessary to check some parts at least annually.

Thermal temperature protection

If the temperature guard is not closed when cold but still leaks water, this is caused by overheating over dirt that has accumulated. Once this is the case, one can press the red button of the temperature guard several times which will flush this guard clean.

Please note that overheating and indentation of the temperature protection device may cause it to malfunction. As a result, this part may need to be replaced.

Wood as a fuel

Only wood that is sufficiently dry, cleaved and clean is suitable for use in a Nordic Fire wood stove.

Do not use wet wood. This is wasted energy (50% less energy!) and it pollutes your stove AND chimney, increasing the risk of chimney fire.

Avoid nuisance. Do not fire during foggy days.

Wood suitable for stoking a wood-burning stove

It is important to use dry wood. Split wood is dry after the wood has dried in the air under a canopy for at least 2 years, leaving a residual moisture of 15% to 19%. Oak wood should be dried for at least 5 years before reaching these residual moisture values. We recommend not using oak or other hardwoods!

The performance of your stove strongly depends on the quality and amount of residual moisture in the wood. The more moisture present in the wood, the more energy is required to evaporate residual moisture. As a result, there is very little residual energy left in the wood. Wet wood is wasted energy.

Wet wood causes greater deposits in your stove and chimney. In addition, it is much more environmentally damaging than dry wood. Firing with insufficiently dry wood leads to possible chimney fires!

The type of wood also determines the amount of energy that can be released. Light wood types give off the energy quickly, while hardwood gives off the energy more slowly. The following table shows the different types of wood and their energy values.

Hardwood	kWh/kg	Wood	kWh/kg
Birch	4.30	Spar	4.50
Beech	4.00	Pine	4.50
Oak	4.20	Den	4.50

Lighter woods burn faster and give off heat faster by reaching higher temperatures faster. Lighter woods are therefore better suited when heating the stove. Hardwood burns slower and therefore you can stoke longer without topping up.

A disadvantage of hardwood is that these types of wood are harder to dry. In practice, hardwood often contains too much residual moisture. This affects the operation of the boiler wood stove. Hardwood is not optimal for use with a central heating stove.

A few tips

- Wood should be stored split.
- Firewood should be stored in a windy place, protected from rain.
- Hardwood should dry longer than lighter woods
- Damp wood is wasted energy. It pollutes your chimney and causes nuisance in the surrounding area.

Only wood that is suitable should be used in the wood stove. Never use the following types of wood:

- Damp wood, or impregnated wood/hardwood
- Varnished wood or wood with a plastic protective coating
- Chipped wood
- Chipboard remnants
- Coal
- Waste
- Paper and cardboard

It is important not to use your stove as a waste incinerator. Burning waste releases toxic substances. These lodge in your chimney, but also spread into your living environment

How much wood can you fire?

Use only the amount of wood in your stove, which is necessary for the heat required at the time.

To achieve the output of your stove, you need the prescribed amount of wood. Overfilling will lead to overheating and damage to your stove. Normally, the right amount of wood is fully burnt after about 45 minutes.

Overfilling leads to damage to the vermiculite, retaining plate and fire grate. If these parts are found to be defective within a few years, this is due to overheating of the wood stove. This leads to additional replacement costs.

Cleaning and maintenance

Normal maintenance

Normal maintenance is maintenance you perform yourself when using the stove.

Cleaning the glass window

The Nordic Fire boiler wood stove is constructed so that the secondary air supply ensures that the glass pane is cleaned. Due to the high temperature and this air supply, dirt particles are burned as much as possible. With the right fuel (dry), sufficient chimney draught, the window remains largely clean. However, a slight deposit cannot be avoided. Poor combustion (e.g. due to wet wood) results in dark deposits not only on the window, but also in the stove itself and the flue gas duct. Deposits caused by wet wood are difficult to remove and may lead to a greater risk of chimney fire. Cleaning the window should only be done with water, using a non-scratch cloth.

Cleaning of painted parts

Gelakte delen kunnen alleen met een droge doek worden gereinigd. Zonder schoonmaakmiddel.

Cleaning the inside and heat exchanger

The heat exchanger will eventually show deposits, which will partly depend on heating behaviour. With wet wood, deposits will build up faster and more frequently. These deposits can be removed once a year by brushing the heat exchanger with a light steel brush. This will largely remove the deposits and creosote residues. Removing these residues will improve the absorption of heat in the central heating system.

Cleaning too often or using harsh agents (abrasives) can cause the heat exchanger to leak, despite being made of extra thick heavy steel.

Special maintenance

Special maintenance should be carried out annually. This is often combined with sweeping the flue.

Maintenance of seals

Sealed doors and glass are subjected to high thermal loads. It is therefore necessary to have these checked once a year by your dealer. If damaged, these seals should be replaced.

Cleaning the fireplace and flue system

At least once a year, the fireplace should be completely cleaned. This can possibly be carried out in combination with cleaning the chimney.

Mounting glass pane

At least once a year, check that all screws securing the glass are tight. If they are loose, you can tighten them by hand.

Door closure

If the door is more difficult to close, we recommend greasing the closing mechanism. This can be done with a heat-resistant grease or copper grease.

Vermiculite or chamotte stone

Cracks in chamotte stone or vermiculite cladding develop over time. These do not need to be replaced unless loose parts fall out. This is normal for a wood-burning stove and is therefore not covered by the guarantee.

Warranty conditions

5-year guarantee on the heat exchanger of Nordic Fire fireplaces

Thanks to the high quality, we can offer as much as a 5-year guarantee on the heat exchanger of Nordic Fire fireplaces. Moreover, our fireplaces are CE approved for all Euro countries.

The purchase date must be evidenced by a copy of the purchase receipt.

Should a defect occur within the guarantee period, at the base of the stove itself, which is the result of a material and/or manufacturing fault, then Nordic Fire bv is prepared to send the part to which the fault has been found to the installer for replacement free of charge without compensation from us for disassembly and assembly. Any freight costs will be at your expense.

If the fault on the appliance is of such a nature that the installer cannot rectify it, then Nordic Fire bv is only prepared to take care of this at the request of the installer.

If, due to circumstances, the complete appliance or parts thereof must be sent for evaluation and/or repair, this must be done after prior consultation, enclosing the purchase invoice with the purchase date. In case of home service, the purchase receipt/receipt with purchase date must be shown. Outside the warranty period, labour, material and travel costs will be charged for home service.

The appliance must be installed and connected by a recognised fitter. Installation must be carried out in accordance with national regulations or the enclosed installation or fitting instructions. The installer must make sure in advance that the flue is working properly.

Warranty expires if:

- The fireplace has not been installed by an authorised Nordic Fire dealer or installer.
- The installation deviates from what is prescribed by Nordic Fire. Incorrect installation may cause damage to the stove. It may also cause the system not to heat up sufficiently because the stove cannot dissipate its heat sufficiently. Therefore, correct installation is very important.
- The appliance is used without the appliance being connected to the central heating system The above conditions are not, or only partly, met.
- Changes have been made to the appliance without our prior knowledge.
- The appliance has changed owners.
- The instructions in the user manual have not been followed.
- The appliance has been neglected or roughly treated.
- The original purchase receipt cannot be shown, or if any information on the guarantee certificate or purchase receipt has been changed, crossed out, removed or made illegible.

Deviations

In deviation from point 1, a different warranty period applies to the parts listed below:

- Cooling coil: this should be checked at least once a year for any leaks from the temperature safety device. Water leaks can in fact lead to rusting of the cooling coil.
- Glass: no guarantee.
- Cord and/or gasket: no guarantee.
- Interior lining (e.g. vermiculite / cast iron parts): no guarantee.
- Mechanical moving parts: 1 year warranty.
- Fittings supplied by Nordic Fire: 1 year, with the exception of the temperature safety device and overpressure safety device. The latter parts can break down after the fireplace overheats.
- Wear or discolouration of the paintwork: no guarantee.

For other provisions, please refer to our general terms and conditions.

Service and faults

Despite all the care taken in the production of Nordic Fire fireplaces, it may happen that something is not right. In that case, contact your dealer or installer. In most cases, your dealer or installer will solve the problem immediately.

Your dealer or installer can contact Nordic Fire for advice or the (after)supply of parts. If required, your dealer or installer can use the Nordic Fire service department. In this case, a Nordic Fire technician will visit you to fix the problem. If this falls within the warranty, the parts are covered by your warranty. However, your dealer may charge for the hours worked.